

WT 370 - WT 700

WUMAG PALFINGER



Up and away with WUMAG PALFINGER

Reaching Your Goals with Ease

The innovative truck mounted access platforms by WUMAG PALFINGER cover the complete spectrum of working heights ranging from 37 to 70 m. Their reliability, high quality standards and user-friendliness have been their trademark and guiding principle for decades. Access platforms by WUMAG PALFINGER can be mounted on all standard vehicles. Plus, they offer tailored solutions for any operating requirements. Their flexibility and efficiency on-the-job are maximized by elements such as the telescopic and hanging workman basket and the telescopic articulating boom.



Innovative and Efficient



WT 370



WT 370 Working range

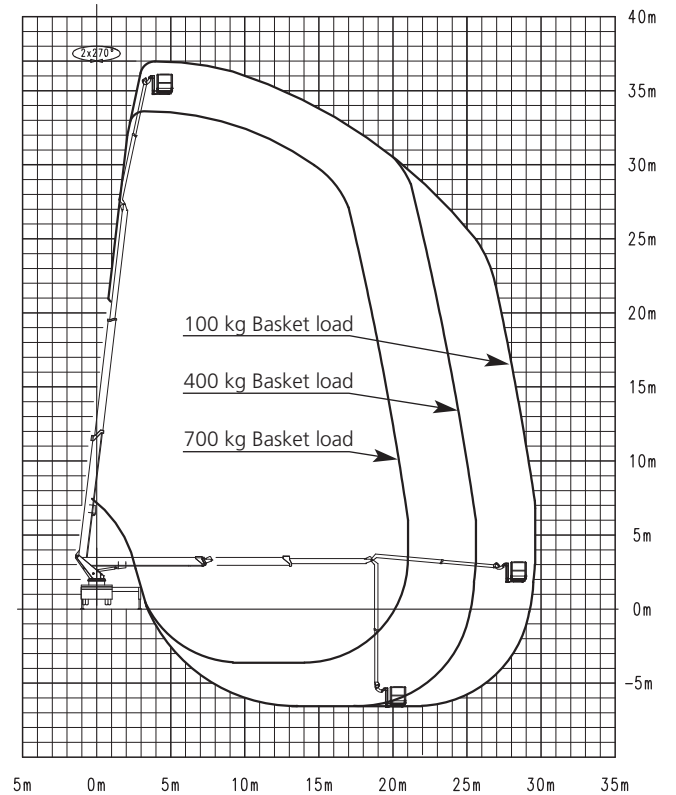
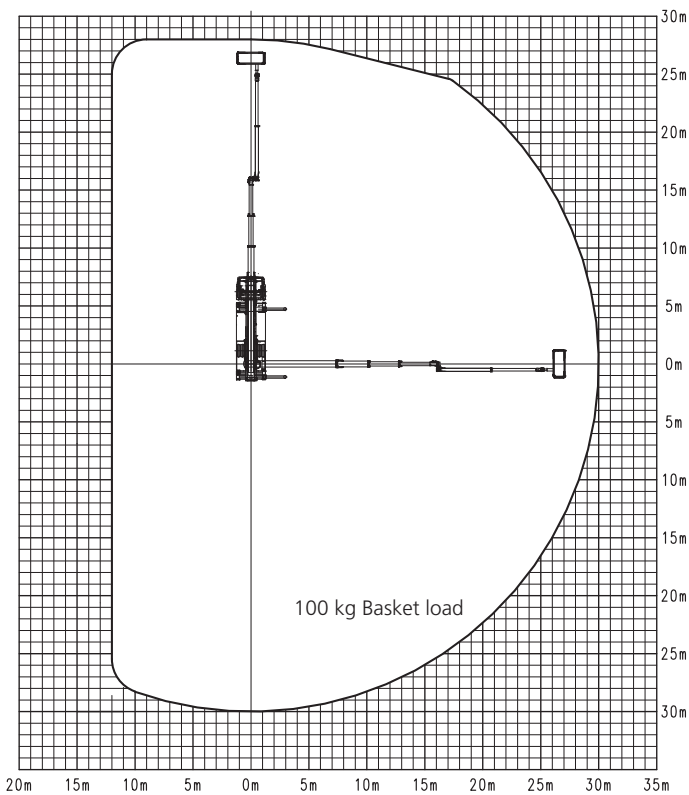

Compact and high-performing

Technical Data WT 370

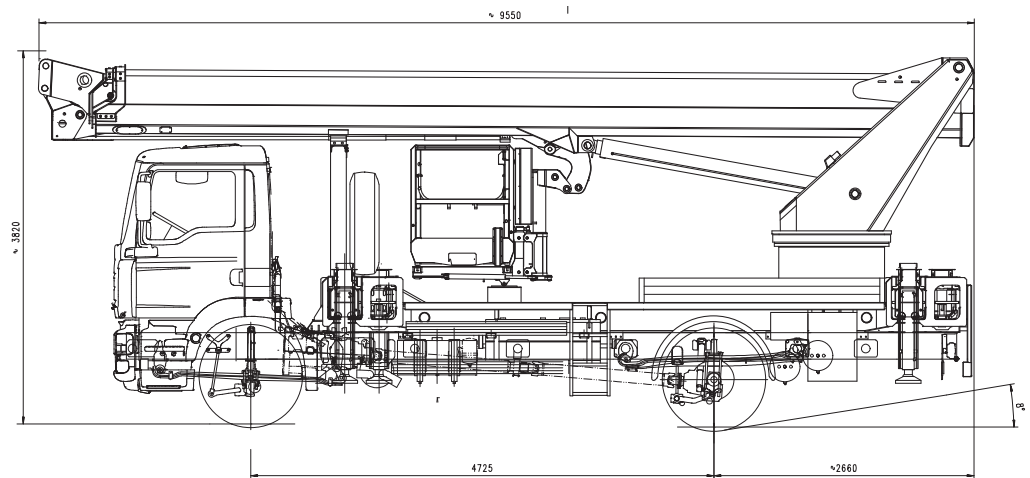

Specifications of basic model

Max. working height	37 m
Max. basket floor height	35 m
Max. horizontal outreach of telescopic workman basket (with ... kg basket load)	28.8 m / 100 kg
Max. horizontal reach Heavy-duty workman basket (with ... kg basket load)	29.50 m / 100 kg

Workman basket

Standard basket:	3.88 x 1.05 x 1.10 m
Telescopic basket (WxLxH)	
Optional basket:	2.47 x 1.05 x 1.10 m
Heavy-duty basket (WxLxH)	
Slewing range of basket	2 x 80°
Max. permissible load with fully extended jib boom	
Telescopic basket	300 kg
Heavy-duty basket	400 kg
Max. permissible load when jib boom is not extended	
Telescopic basket	600 kg
Heavy-duty basket	700 kg
Motor Start/Stop in the workman basket	standard
Synthetic cover on control panel	standard
230 V CEE outlet in the workman basket	standard
5 anchor points to secure safety belt	standard
Displaceable control panel	standard
Graphic display	standard
Reversible slewing direction after panel relocation	standard
Collision protection for basket and jib boom	standard
Battery voltage monitoring in the basket	standard

Stabilizers

Function of the stabilizers	fully variable
Max. stabilizer spread - both sides horizontally extended	6.20 m
Stabilizer control at the base	standard
Automatic outrigger system and set-up levelling	standard
Max. permissible inclination 2°	
Blinking lights on the stabilizer extensions	standard
4 Safety plates	standard

Boom system

Number of extensions (main boom)	2
Jib boom	1 extension
Max. length of jib boom	8.5 m
Working range with jib boom below floor level	up to 6 m
All power guides and hydraulic and mechanical equipment internally routed and optimally protected against damage	standard
Hydraulic jib boom, working range	175°
Automatic return of main boom to transport position "Home Function"	standard

Slewing system

Slewing within mirror width	standard
Slewing range	540°

Carrier vehicle and installation

GVW class	at least 18 t
Length in transport position	9.55 m*
Width in transport position	2.50 m*
Height in transport position	3.70 m*
Angle of slope	approx. 8° *
Hydraulic oil tank with return line filter	standard

*) depending on carrier vehicle

Manual and emergency controls

Integrated in the body - well-protected and lockable	standard
Emergency lowering system in the basket	standard
Back-up/Emergency control at the base	standard
24 V electric emergency pump over vehicle battery	standard

WT 450



WT 450 Working range

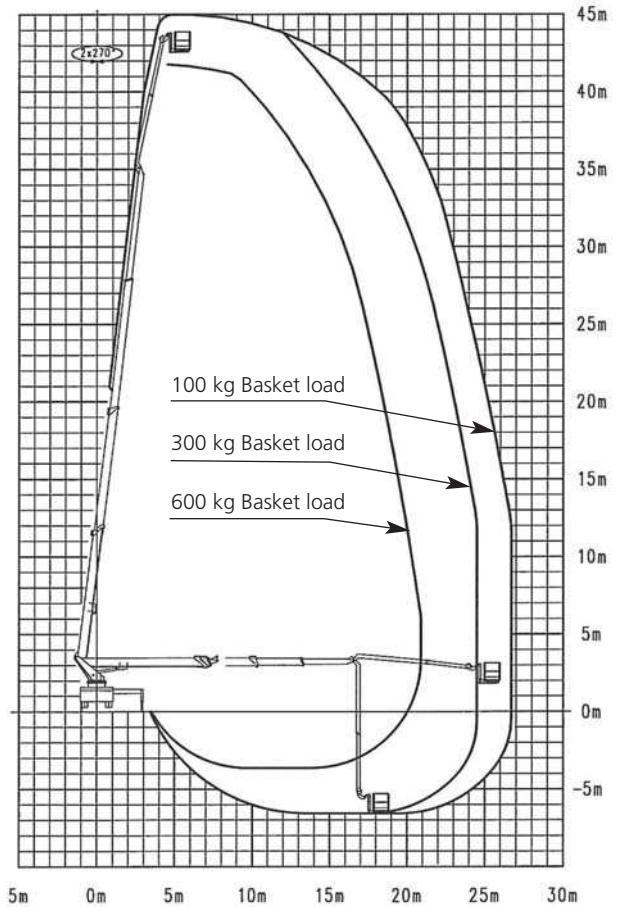
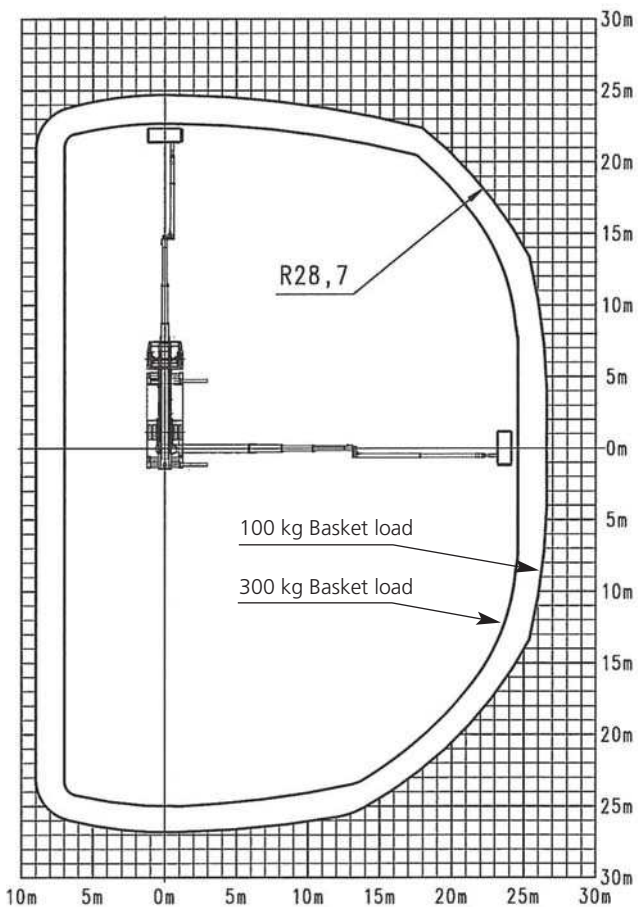

Versatile on-the-job

Technical Data WT 450

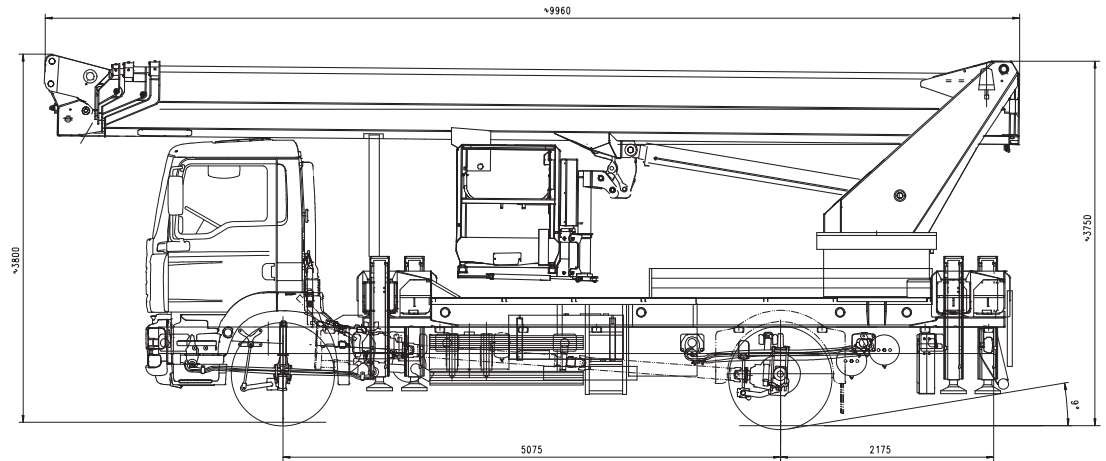

Specifications of basic model

Max. working height	45 m
Max. basket floor height	43 m
Max. horizontal outreach of telescopic workman basket (with ... kg basket load)	28.7 m / 100 kg
Max. horizontal reach Heavy-duty workman basket (with ... kg basket load)	29.5 m / 100 kg

Workman basket

Standard basket:	
Telescopic basket (WxLxH)	3.88 x 1.05 x 1.10 m
Optional basket:	
Heavy-duty basket (WxLxH)	2.47 x 1.05 x 1.10 m
Slewing range of basket	2 x 80°
Max. permissible load with fully extended jib boom	
Telescopic basket	300 kg
Heavy-duty basket	400 kg
Max. permissible load when jib boom is not extended	
Telescopic basket	600 kg
Heavy-duty basket	700 kg
Motor Start/Stop in the workman basket	standard
Synthetic cover on control panel	standard
230 V CEE outlet in the workman basket	standard
5 anchor points to secure safety belt	standard
Displaceable control panel	standard
Graphic display	standard
Reversible slewing direction after panel relocation	standard
Collision protection for basket and jib boom	standard
Battery voltage monitoring in the basket	standard

Stabilizers

Function of the stabilizers	fully variable
Max. stabilizer spread - both sides horizontally extended	6.20 m
Stabilizer control at the base	standard
Automatic outrigger system and set-up levelling	standard
Max. permissible inclination 2°	
Blinking lights on the stabilizer extensions	standard
4 Safety plates	standard

Boom system

Number of extensions (main boom)	3
Jib boom	1 extension
Max. length of jib boom	8.5 m
Working range with jib boom below floor level	up to 6 m
All power guides and hydraulic and mechanical equipment internally routed and optimally protected against damage	standard
Hydraulic jib boom, working range	175°
Automatic return of main boom to transport position "Home Function"	standard

Slewing system

Slewing within mirror width	standard
Slewing range	540°

Carrier vehicle and installation

GVW class	at least 18 t
Length in transport position	10 m*
Width in transport position	2.50 m*
Height in transport position	3.70 m*
Angle of slope	approx. 9° *
Hydraulic oil tank with return line filter	standard

*) depending on carrier vehicle

Manual and emergency controls

Integrated in the body - well-protected and lockable	standard
Emergency lowering system in the basket	standard
Back-up/Emergency control at the base	standard
24 V electric emergency pump over vehicle battery	standard

WT 530



WT 530 Working range

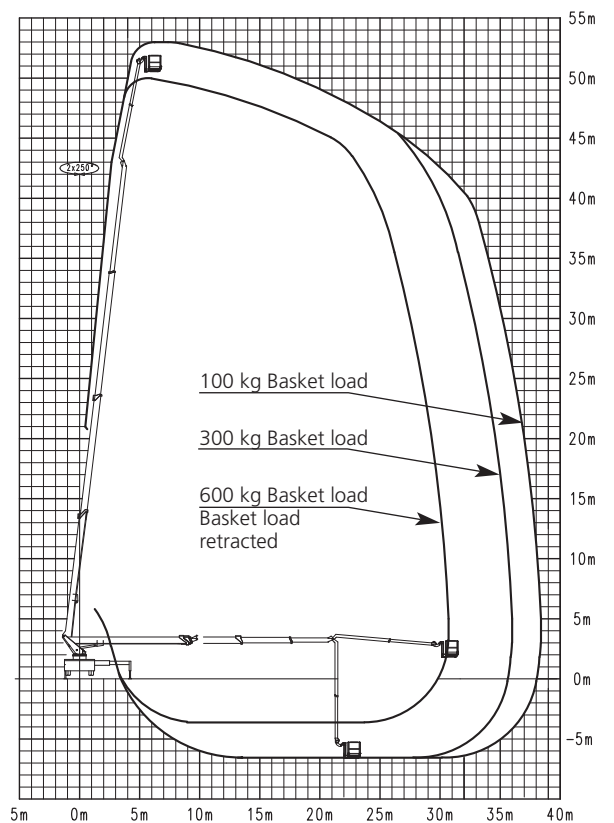
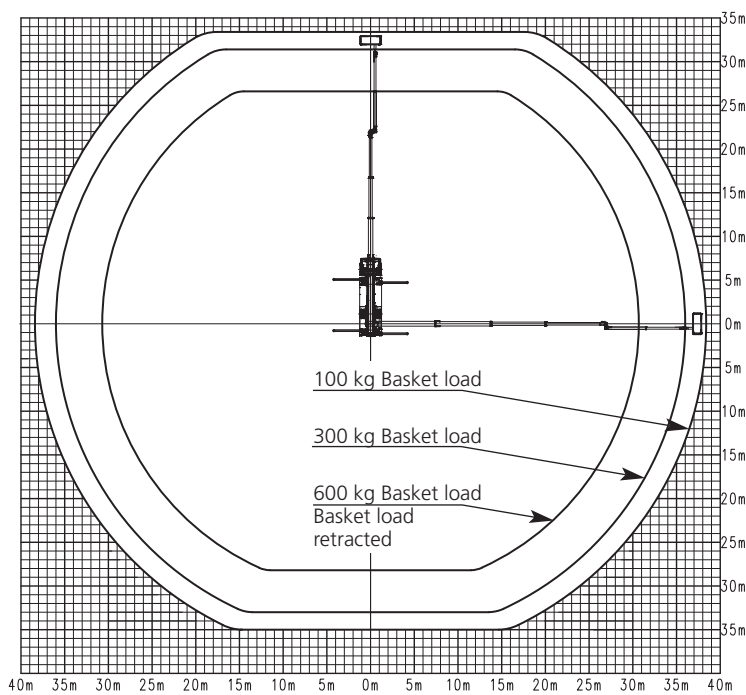

High Nominal Load

Technical Data WT 530

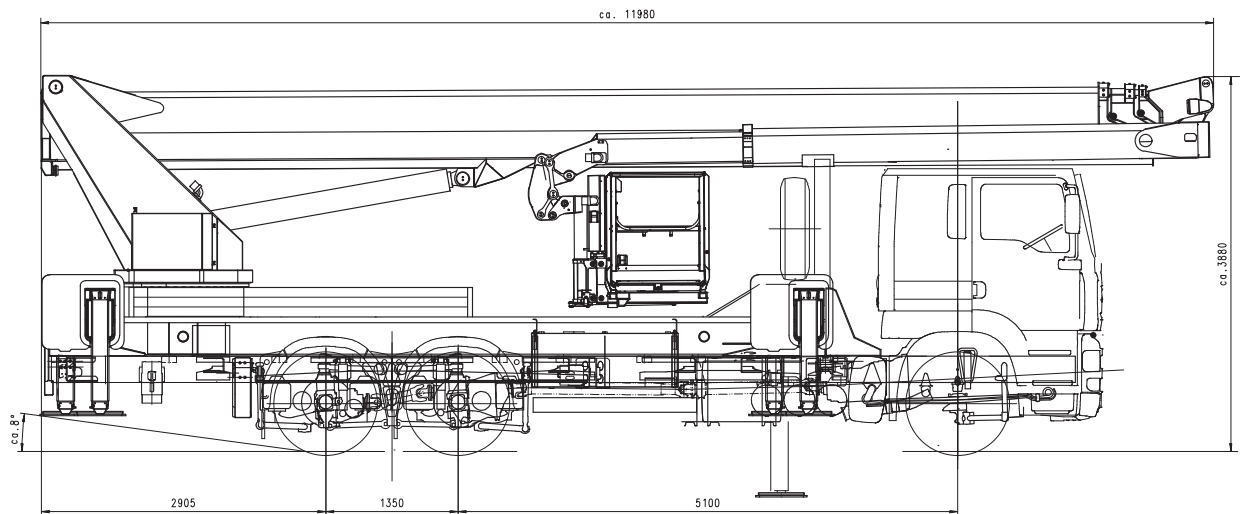

Specifications of basic model

Max. working height	53 m
Max. basket floor height	51 m
Max. horizontal outreach of telescopic workman basket (with ... kg basket load)	38.3 m / 100 kg
Max. horizontal reach Heavy-duty workman basket (with ... kg basket load)	39 m / 100 kg

Workman basket

Standard basket:	3.88 x 1.05 x 1.10 m
Telescopic basket (WxLxH)	
Optional basket:	2.47 x 1.05 x 1.10 m
Heavy-duty basket (WxLxH)	
Outreach with straight position of basket	30 m / 100 kg
Slewing range of basket	2 x 80°
Max. permissible load with fully extended jib boom	
Telescopic basket	300 kg
Heavy-duty basket	400 kg
Max. permissible load when jib boom is not extended	
Telescopic basket	600 kg
Heavy-duty basket	700 kg
Motor Start/Stop in the workman basket	standard
Synthetic cover on control panel	standard
230 V CEE outlet in the workman basket	standard
5 anchor points to secure safety belt	standard
Displaceable control panel	standard
Graphic display	standard
Reversible slewing direction after panel relocation	standard
Collision protection for basket and jib boom	standard
Battery voltage monitoring in the basket	standard

Stabilizers

Function of the stabilizers	fully variable
Max. stabilizer spread - both sides horizontally extended	8.67 m
Stabilizer control at the base	standard
Automatic outrigger system and set-up levelling	standard
Max. permissible inclination 2°	
Blinking lights on the stabilizer extensions	standard
4 Safety plates	standard

Boom system

Number of extensions (main boom)	3
Jib boom	1 extension
Max. length of jib boom	8.5 m
Working range with jib boom below floor level	up to 6 m
All power guides and hydraulic and mechanical equipment internally routed and optimally protected against damage	standard
Hydraulic jib boom, working range	175°
Automatic return of main boom to transport position "Home Function"	standard

Slewing system

Slewing within mirror width	standard
Slewing range	540°

Carrier vehicle and installation

GVW class	at least 26 t
Length in transport position	12 m*
Width in transport position	2.50 m*
Height in transport position	3.90 m*
Angle of slope	approx. 8° *
Hydraulic oil tank with return line filter	standard

*) depending on carrier vehicle

Manual and emergency controls

Integrated in the body - well-protected and lockable	standard
Emergency lowering system in the basket	standard
Back-up/Emergency control at the base	standard
24 V electric emergency pump over vehicle battery	standard

WT 610



WT 610 Working range

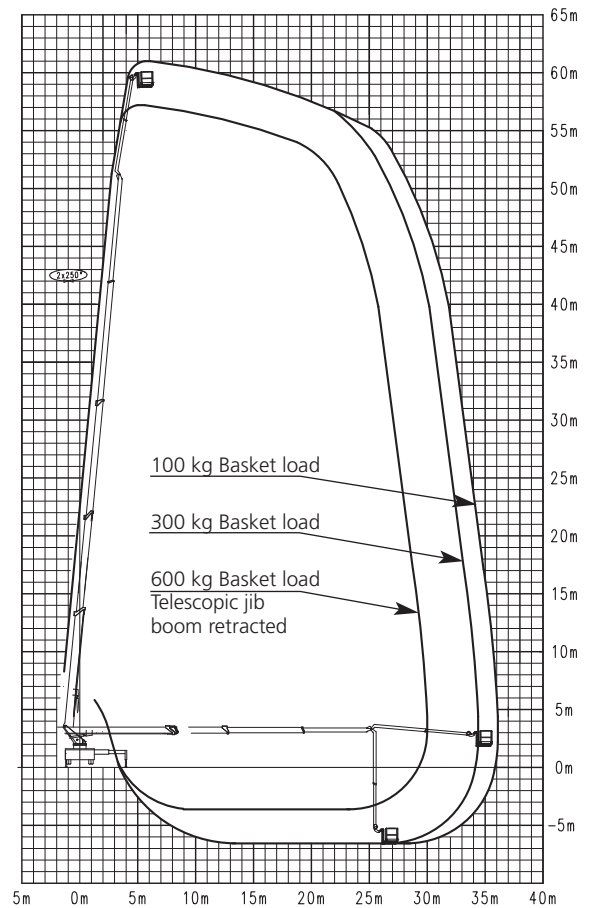
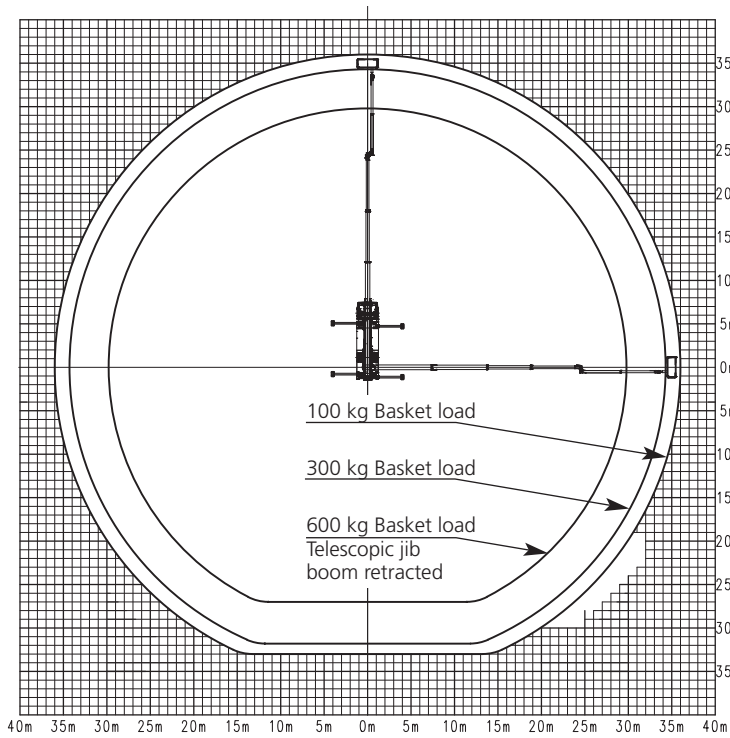

Robust Performer

Technical Data WT 610

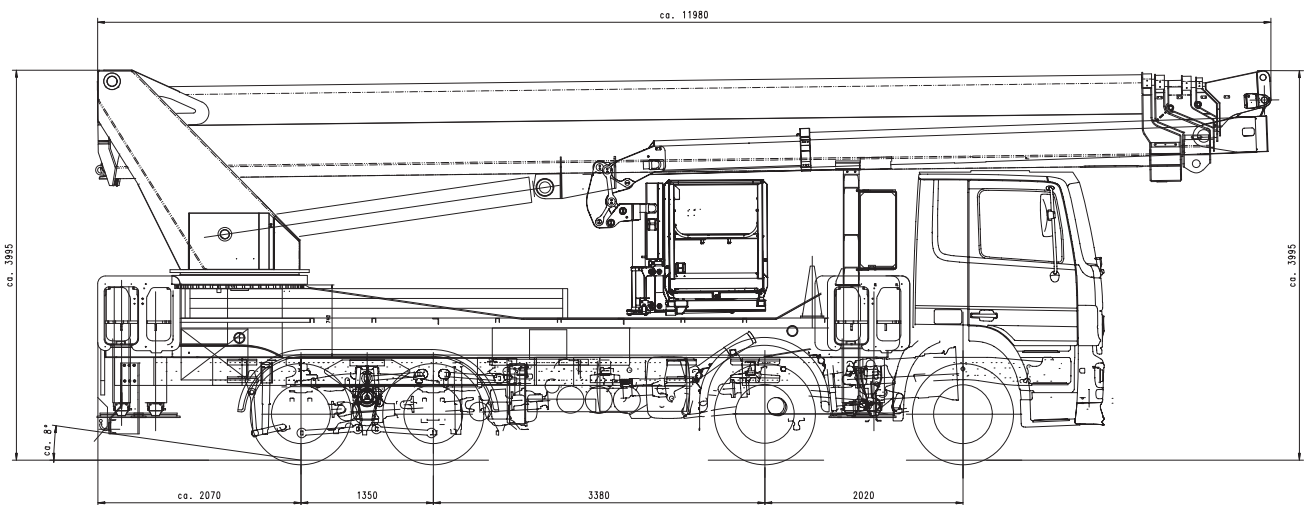

Specifications of basic model

Max. working height	61 m
Max. basket floor height	59 m
Max. horizontal outreach of telescopic workman basket (with ... kg basket load)	36.8 m / 100 kg
Max. horizontal reach Heavy-duty workman basket (with ... kg basket load)	37.5 m / 100 kg

Workman basket

Standard basket:	3.88 x 1.05 x 1.10 m
Telescopic basket (WxLxH)	
Optional basket:	2.47 x 1.05 x 1.10 m
Heavy-duty basket (WxLxH)	
Outreach with straight position of basket	30 m / 100 kg
Slewing range of basket	2 x 80°
Max. permissible load with fully extended jib boom	
Telescopic basket	300 kg
Heavy-duty basket	400 kg
Max. permissible load when jib boom is not extended	
Telescopic basket	600 kg
Heavy-duty basket	700 kg
Motor Start/Stop in the workman basket	standard
Synthetic cover on control panel	standard
230 V CEE outlet in the workman basket	standard
5 anchor points to secure safety belt	standard
Displaceable control panel	standard
Graphic display	standard
Reversible slewing direction after panel relocation	standard
Collision protection for basket and jib boom	standard
Battery voltage monitoring in the basket	standard

Stabilizers

Function of the stabilizers	fully variable
Max. stabilizer spread - both sides horizontally extended	8.27 m
Stabilizer control at the base	standard
Automatic outrigger system and set-up levelling	standard
Max. permissible inclination 1°	
Blinking lights on the stabilizer extensions	standard
4 Safety plates	standard

Boom system

Number of extensions (main boom)	4
Jib boom	1 extension
Max. length of jib boom	8.5 m
Working range with jib boom below floor level	up to 6 m
All power guides and hydraulic and mechanical equipment internally routed and optimally protected against damage	standard
Hydraulic jib boom, working range	175°
Automatic return of main boom to transport position "Home Function"	standard

Slewing system

Slewing within mirror width	standard
Slewing range	540°

Carrier vehicle and installation

GVW class	at least 32 t
Length in transport position	12 m*
Width in transport position	2.50 m*
Height in transport position	3.90 m*
Angle of slope	approx. 8° *
Hydraulic oil tank with return line filter	standard

*) depending on carrier vehicle

Manual and emergency controls

Integrated in the body - well-protected and lockable	standard
Emergency lowering system in the basket	standard
Back-up/Emergency control at the base	standard
24 V electric emergency pump over vehicle battery	standard

WT 700



WT 700 Working range

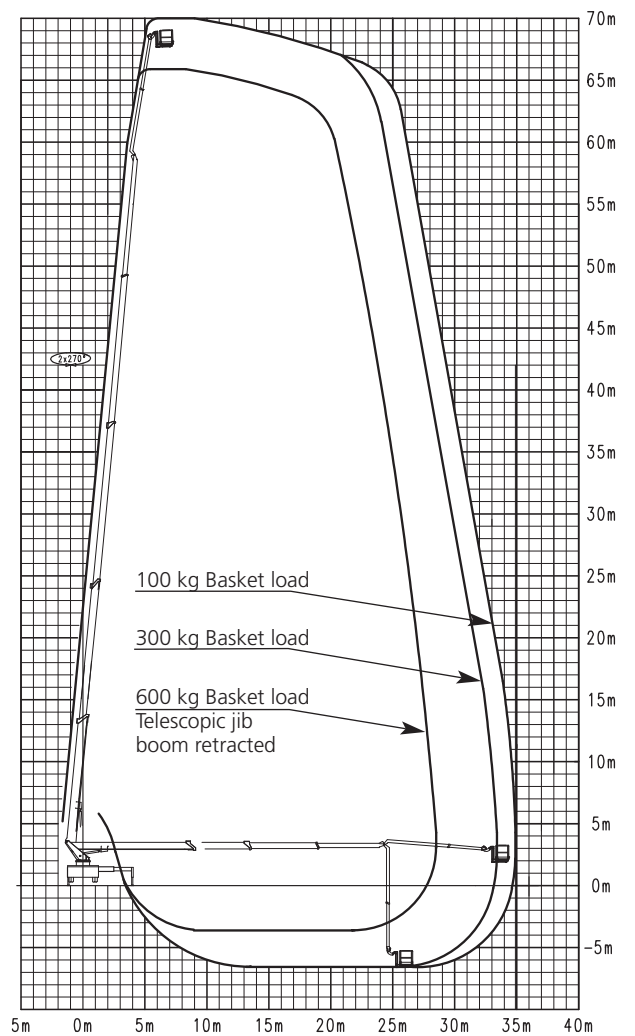
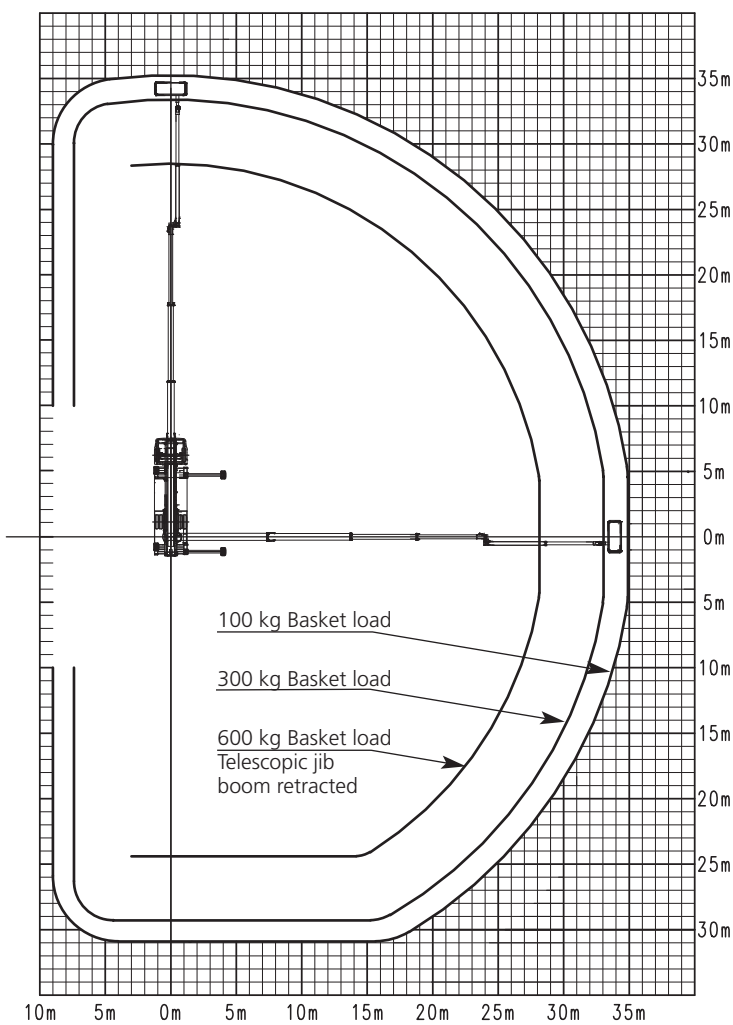

For Great Working Heights

Technical Data WT 700

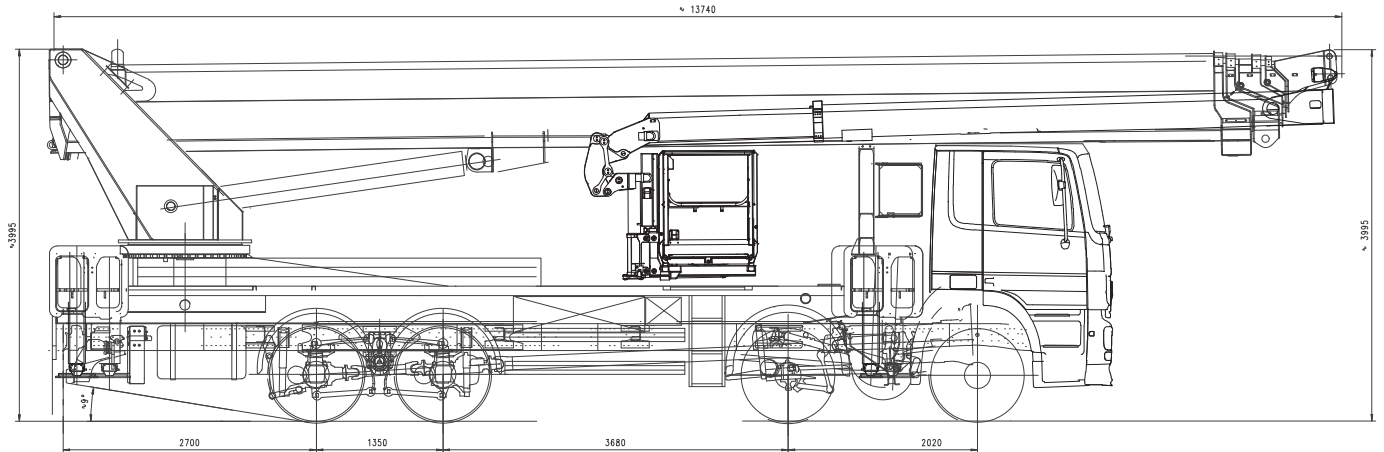

Specifications of basic model

Max. working height	70 m
Max. basket floor height	68 m
Max. horizontal outreach of telescopic workman basket (with ... kg basket load)	35.0 m / 100 kg
Max. horizontal reach Heavy-duty workman basket (with ... kg basket load)	35.7 m / 100 kg

Workman basket

Standard basket:	3.88 x 1.05 x 1.10 m
Telescopic basket (WxLxH)	
Optional basket:	2.47 x 1.05 x 1.10 m
Heavy-duty basket (WxLxH)	
Outreach with straight position of basket	30 m / 100 kg
Slewing range of basket	2 x 80°
Max. permissible load with fully extended jib boom	
Telescopic basket	300 kg
Heavy-duty basket	400 kg
Max. permissible load when jib boom is not extended	
Telescopic basket	600 kg
Heavy-duty basket	700 kg
Motor Start/Stop in the workman basket	standard
Synthetic cover on control panel	standard
230 V CEE outlet in the workman basket	standard
4 anchor points to secure safety belt	standard
Displaceable control panel	standard
Graphic display	standard
Reversible slewing direction after panel relocation	standard
Collision protection for basket and jib boom	standard
Battery voltage monitoring in the basket	standard

Stabilizers

Function of the stabilizers	fully variable
Max. stabilizer spread - both sides horizontally extended	8.27 m
Stabilizer control at the base	standard
Automatic outrigger system and set-up levelling	standard
Max. permissible inclination 1°	
Blinking lights on the stabilizer extensions	standard
4 Safety plates	standard

Boom system

Number of extensions (main boom)	4
Jib boom	1 extension
Max. length of jib boom	9.65 m
Working range with jib boom below floor level	up to 6 m
All power guides and hydraulic and mechanical equipment internally routed and optimally protected against damage	standard
Hydraulic jib boom, working range	175°
Automatic return of main boom to transport position "Home Function"	standard

Slewing system

Slewing within mirror width	standard
Slewing range	540°

Carrier vehicle and installation

GVW class	33 t
Length in transport position	13.75 m*
Width in transport position	2.50 m*
Height in transport position	3.98 m*
Angle of slope	approx. 9° *
Hydraulic oil tank with return line filter	standard

*) depending on carrier vehicle

Manual and emergency controls

Integrated in the body - well-protected and lockable	standard
Emergency lowering system in the basket	standard
Back-up/Emergency control at the base	standard
24 V electric emergency pump over vehicle battery	standard

Powerful Arguments



Telescopic Workman Basket

The workman basket has a slewing area of 175°. The extension of the fully adjustable telescopic basket takes place electro-hydraulically from the display. Since the control panel is displaceable, the control functions of the slewing can be changed according to the position of the control panel. The basket itself is equipped with an open railing which enables easy access. The tool tray is perfectly integrated into the basket and does not restrict the operator's movement.



Hanging Basket System

The basket with the hanging overhead suspension system makes it possible to move over obstacles more precisely, thereby avoiding collisions and damage. The basket can then be lowered on the other side.



Transport concept: "Powerlift System"

Transporting materials easily and saving time are the advantages of the optional Powerlift System. With this system the extremely high basket capacity can be used efficiently for heavy loads. The Powerlift System is the ideal solution for assembly applications, as well as for lighting and maintenance systems. Due to the exceptional performance of WUMAG jib booms, the workman basket can be loaded with materials right over the ground and lift them easily over any obstacles.



Telescopic Articulating Booms

The standard 2-section telescopic articulating booms can always be extended to the greatest possible degree, according to the load. This enables utmost flexibility for any job. The load in the basket is fully adjustable in accordance with the current boom length.



Efficient Control System

In order to work efficiently, operators need a perfect control system right in their workman basket. In addition to displaying the most important technical data graphically, the system can also display all help and warning instructions in text format. Standard functions include the home function, the speed regulator (depending upon operating position), reverse, and the fully adjustable rabbit-turtle function. Electronic comfort functions are further options which enable operators to optimize performance. These include the memory function and the equalizer with individually adjustable characteristics for vehicle movement. All platforms come equipped with an electronic back-up control on the base and an emergency control (emergency lowering system) in the basket.

The Details of Success

Hydraulics

The proper oil temperature is essential for smooth operation and, therefore, needs to be constantly monitored. In case of increased oil temperature, a safety control automatically activates an integrated cooling system.
Load-bearing cylinders are equipped with redundant block valves.



Internal routing

All power guides, chains, cables and telescopic cylinders are internally routed in the boom system. This provides optimal protection against damage and weather. The vehicle's outer appearance is marked by smooth surfaces and a clear alignment.



Fully adjustable stabilizers – Slewing within the vehicle width

The crank of the column enables slewing within the contours of the exterior mirrors of the vehicle.
Fully adjustable and automatically leveled stabilizers optimize the working range.
The column incline is also monitored and the potential working range automatically calculated.



Safety ground pads

The innovative safety ground pads guarantee the securest grounding and the optimal pressure distribution on the floor. This important component between the platform and the ground comes standard.



Servicefriendliness

Comprehensive service functions are integral to our access platforms: operating-hour meter, remote maintenance, error file memory, freely programmable height limitation, diagnostic tools and remote diagnostic devices via wireless modem and remote maintenance systems.
To ensure readily available supplies, the electronic components of models ranging from the WT 230 up to the WT 700 are the same whenever possible.



Your Reliable Partner

KP-WT370/700M1+E
E 09/08, K 09/08, D 04/10



Krefeld – Germany